



Project: _____

Location: _____

Item #: _____

Quantity: _____

GAS BOILERLESS MOBILE CATERING STEAMER

MODEL: POLARIS - 4



Polaris - 4 Pan Shown on Mobile Stand and 30 lb. Propane Tank

Specifications:

Polaris is a Stellar Steam boilerless steam oven efficiently heated by a burner external to the water reservoir. The steamer operates without an external electric source. The electricity required by the controls is generated by the steamer. The Polaris steamer is protected from low-water conditions and is also thermally protected. No plumbing, drain line or electricity are required making this appliance ideal for the catering market. Polaris steamers use 29,500 BTU/H per unit

Cooking Compartment:

Operation occurs from steam generated in the cooking compartment. The walls and ceiling of the cooking compartment are heated to reduce steam condensing on these surfaces and to reheat and revitalize partially condensed steam. The cooking compartment is constructed of cast aluminum with a food-grade non-stick hard anodized finish. The cooking compartment acts as a heat sink, allowing for heat retention, quick recovery, and reduced energy consumption.

Controls:

Standard controls are in English and Spanish. No electricity is required for steamer operation. Gas flow is controlled by millivolt gas components. The gas valve incorporates a pilot safety in the event of a pilot outage. Gas is closed off to the burner and pilot when the pilot safety closes. The steamer is protected from low water condition; when levels get too low the gas valve shuts off supply of gas to the burner. The steamer is thermally protected; if the cooking compartment gets too hot, the gas valve shuts off gas supply to the burner. The Polaris has an on/off switch on the control panel. The switch is used to shut main burner flame off during slow periods without shutting off the pilot. The pilot flame keeps water in the reservoir warm during off time promoting faster recovery time. The unit can be lit

Doors:

The door is field reversible with a flush panel latch and is fully insulated.

Standard Features:

» Controls:

- » On/Off Switch - Turns off Main Burner Flame, Pilot stays on.
- » Millivolt Combination Gas Valve.
- » Piezo Ignitor.

» Construction:

- » 30 lb. Propane Tank with Regulator Mounted to Mobile Stand.
- » Mobile Stand.
- » 304 Stainless, #4 Finish (*Cabinet*)
- » 356.1 Aluminum Cast Cooking Compartment with Hard-Anodized Finish.

- Front Drain
- Redundant Safety Systems
- UL/CUL Safety & Sanitary (*NSF-4*)
- No External Electric Source Required.
- One-Year Parts and Service

Options and Accessories:

- Additional 30 lb. Propane Tank.

Approvals:



SPEC SHEET: S-6061 02/2009

www.stellarsteam.com

CHARACTERISTICS

POLARIS - 4

Width, Overall	24"
Depth, Overall	28.75"
Height, , Overall + Legs	26.25 + 34.5"
Depth, Doors Open 90°	46.5"
No. of Doors	1
No. of Compartments	1
Pan Capacity (12" x 20" x 2.5")	4
Pan Capacity (12" x 20" x 4")	2
Gas BTU/hr	26,000
Gas Pressure (<i>propane</i>) inlet	11" WC required, not to exceed 13.5"

NOTE:

- 4" clearance left mandatory, right and rear is recommended.

Crated Dim. & Wts.	Height	Width	Depth	Cu.Ft.	Lbs.
Polaris - 4	68.25"	34.25"	43"	58.2"	255

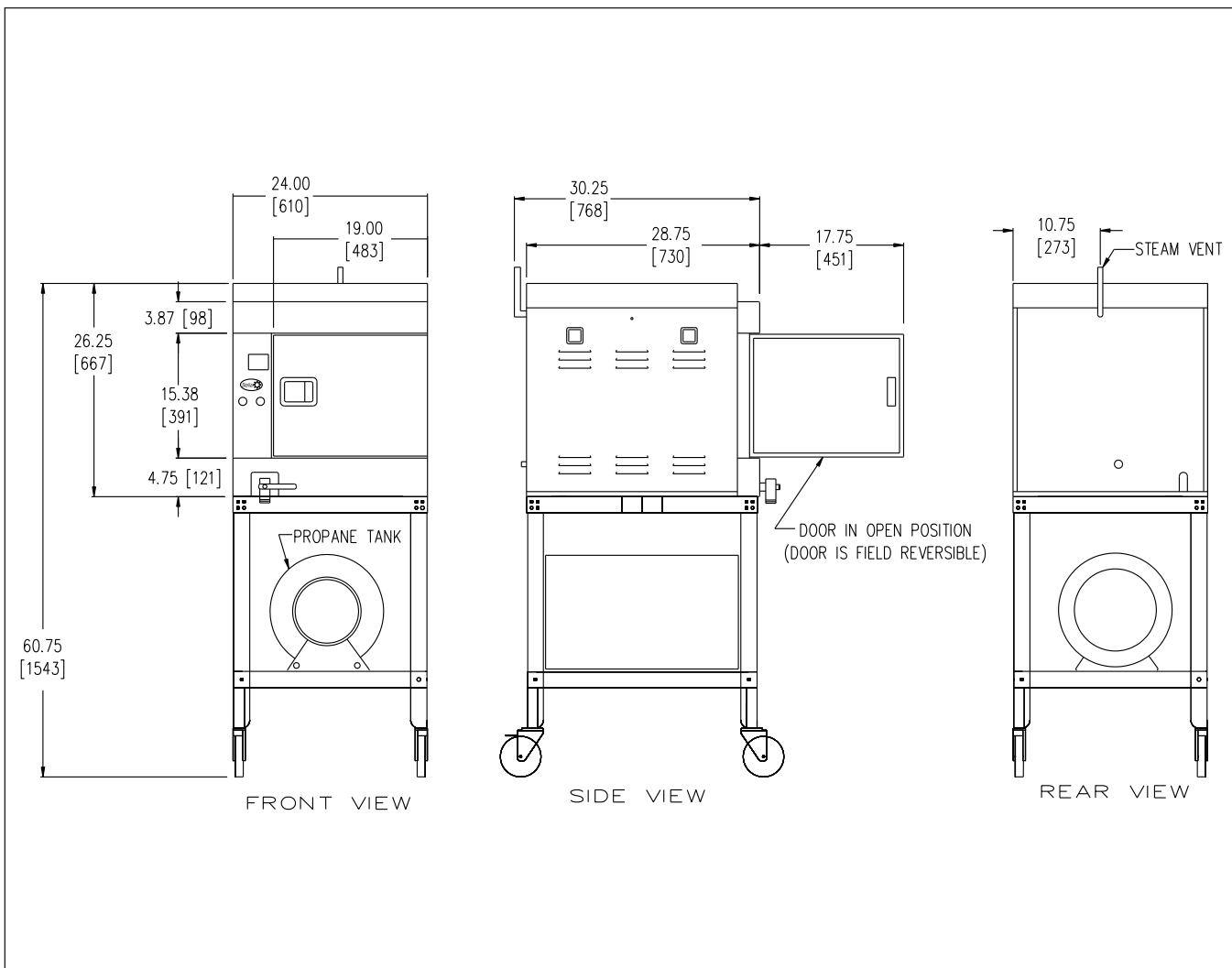

Continuous product development may necessitate specification changes and design without notice.



Stellar Steam participates in the KCL CADalog, the most current source of CAD symbols for foodservice designers worldwide. Symbols include standard equipment in plan, side, front and 3-D views, layered for FEDA/FCSI recommended guidelines.